

TYCO

4-4-0 GENERAL

No.5® TENDER COUPLER CONVERSION

1. Remove existing coupler, save screw.
2. Assemble No.5® Coupler with Centering Spring on top. Install Coupler onto tender from below and secure with Tyco screw. Manufacturing variations may cause you to have to file away some material to make a notch for the No.5® Draft Gear Box to fit in and lay flat or you may have to place a shim under box to obtain the correct coupler mounting height.
3. Check for correct coupler height, function, and clearance and make any adjustments necessary.

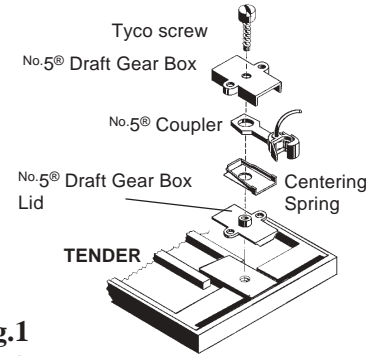

Fig.1
No.5® Tender Installation