

# TYCO

# 4-6-2 PACIFIC

## #39 PILOT, #37 TENDER COUPLER CONVERSION

1. Remove existing couplers, save screws.
2. Check the pilot coupler opening with the 30-Series Draft Gear Box. If not wide enough, remove material equally from both sides until opening is 5/16" wide.
3. For pilot: Assemble the #39 Coupler with Torsion Spring on top, Coupler on bottom. Install #39 Coupler in pilot from the front and secure with Tyco screw.
4. For tender: Assemble #37 Coupler with Torsion Spring on top, Coupler on bottom. Install #37 Coupler onto tender from below and secure with Tyco screw.
5. Check for correct coupler height, function, and clearance and make any adjustments necessary.

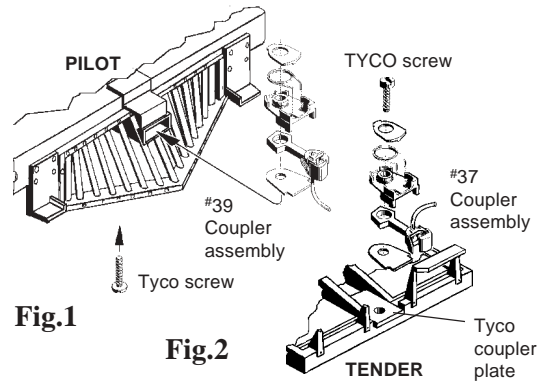

**Fig.1**

**Fig.2**

**#39 Pilot, #37 Tender Installation**