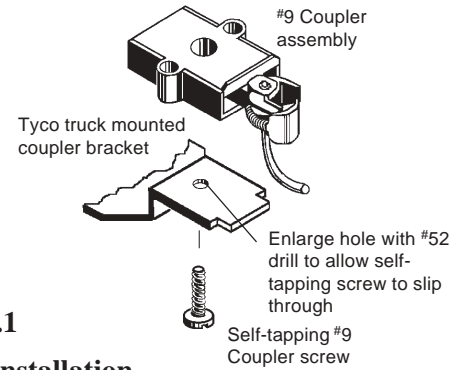

TYCO**#9 COUPLER CONVERSION**

1. Remove trucks and existing couplers from loco.
2. To remove couplers, file away the bottom side of rivet burr holding Tyco coupler to coupler mounting platform. Pry away coupler cover and remove.
3. Enlarge mounting hole in coupler platform with a #52 drill to allow screw provided with #9 Coupler to slip through hole.
4. Assemble the #9 Coupler per instructions. Place on top of the coupler mounting platform and secure with self-tapping screw provided with #9 Couplers.
5. Check for correct coupler height, function, and clearance and make any adjustments necessary.

EMD GP-20**Fig.1****#9 Installation**