

YE OLD HUFF-N-PUFF

ALL ROLLING STOCK

No.5® COUPLER CONVERSION

1. Remove existing coupler and draft gear box if already assembled.
2. Assemble the No.5® Coupler with Centering Spring on top. Place Lid on Draft Gear Box and glue together. Use a plastic compatible cement applied sparingly along seams only.
3. Align coupler assembly on car centerline and secure to coupler mounting platform with a screw.
4. Check for correct coupler height, function, and clearance and make any adjustments necessary.

Secure No.5® Coupler assembly to car floor with screw. Be sure coupler is aligned and on car centerline

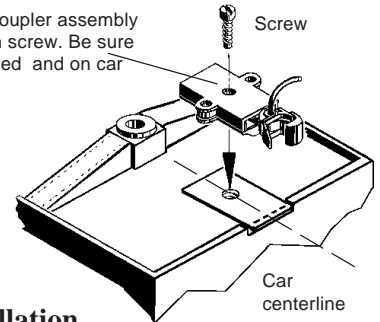

Fig.1

No.5® Installation